

ORIGINAL INSTRUCTIONS

#004-995

GraverMax[®] G8

OPERATION AND MAINTENANCE MANUAL

**READ THIS MANUAL ENTIRELY
BEFORE CONNECTING TO POWER.**

Damage not covered by the warranty may result from not following the instructions and maintenance in this manual.

NOTICE



This engraving system requires clean, dry, oil-free air. An oil-free compressor is recommended for use with this system. For any oil-type compressors, an oil-removal filter (coalescing type) in the air supply line to this engraving system **MUST BE INSTALLED AND IN USE.**

**OIL OR WATER CONTAMINATION
IS NOT COVERED BY WARRANTY.**

For help with ordering or installing an oil-removal filter, or for guidance with operation or maintenance, please contact GRS[®] or an authorized GRS[®] dealer.

To send a request for assistance via electronic formats, e-mail support@glendo.com or visit:

grs.com/contact-us/

Important notes are **highlighted in yellow** or **marked in red**.

Manual Contents

Important Notice For Operators	1
Required Equipment & Important Notes	2
Introduction, Unpacking The Unit	4
Setup & Connections	6
Mount & Connect Air Filter, Connect Foot Throttle, Connect Handpiece(s), Using an Air-Driven Rotary Handpiece, Connect Electrical Power	
Operation	8
Strokes Per Minute (SPM), Fine Adjustments for Handpiece Operation, Handpiece Adjustment Troubleshooting, Foot Throttle Operation, Handpiece Operation, Adjustments Using the Bias Control	
Maintenance	12
Handpiece, Foot Throttle, GRS® Ultra 850 Rotary Handpiece	
Important Notices	13
GRS® Progressive Foot Throttle Owners, Air Contaminants & Water Accumulation	
Service & Repair	14
Parts Lists	15
Wiring, Hose Diagrams	22
Notes	24
Declaration of Conformity	25
Warranty	Back Cover

**READ THIS MANUAL ENTIRELY
BEFORE CONNECTING TO POWER.**

Damage not covered by the warranty may result from not following the instructions and maintenance in this manual.

IMPORTANT NOTICE FOR OPERATORS

Read this manual thoroughly before operation. The manufacturer is not responsible for injury resulting from improper operation or when used by untrained operators.



Do not modify this equipment or remove warning labels. Modifications can increase risks to the operator. Do not use this equipment if it is damaged. This equipment allows the use of small sharp cutting tools that can break suddenly. Always wear eye protection appropriate for each application, and protect hands from sharp edges.

Like other power tools, this device exposes the operator to mechanical vibration. If any user experiences discomfort, pain, numbness, aching, etc., in their hands, fingers, arms, or related joints, discontinue use and consult with an appropriate health professional.

Although this equipment does not generate dust itself, the tools used in the handpieces may do so. When sharpening tools, the user should take appropriate steps to avoid dust inhalation. Certain tool materials generate harmful dust while being ground or sharpened.

The proper use of this equipment does not generate significant or harmful noise emissions.



FOR PROPER OPERATION, THIS SYSTEM REQUIRES:

- Included 24-volt power converter connected to a properly grounded electrical power outlet
- Clean, dry, oil-free air provided by an air compressor
- A compatible GRS® pneumatic handpiece
- A graver or similar tool
- A clean, sturdy work surface with adequate lighting
- Workholding device or material

READ THIS MANUAL ENTIRELY BEFORE CONNECTING TO POWER.

Damage not covered by the warranty may result from not following the instructions and maintenance in this manual.



REQUIRED EQUIPMENT & IMPORTANT NOTES

- **Included 24-volt power converter**

 **USE ONLY THE SUPPLIED 24-VOLT POWER CONVERTER.** The included power converter may be connected to any properly grounded single-phase source of AC power within a voltage range of 100 to 240 V, 50 or 60 Hz. If necessary, use the supplied grounded 2-prong plug adapter or other suitable adapter. The power converter must be used with a suitable grounded electrical system. Using it with an ungrounded system could expose the equipment to electrical damage. Do not use older generation power converters. If a replacement is needed, contact GRS® or an authorized GRS® dealer to order #022-987.

 **DO NOT OPERATE THE MACHINE WITHOUT A COMPRESSED AIR SUPPLY.** Compressed air not only provides the handpiece with power, it lubricates internal components including the rotary air valve. Do not add oil or any lubricant to the compressed air supply.

- **A compatible GRS® pneumatic handpiece**

All GRS® Standard Handpieces (and GRS® Airtact Handpieces with an attached Airtact Control System) are compatible with this system. **DO NOT USE SYSTEM 3 OR GRAVERMEISTER™ HANDPIECES.** Please contact GRS® or an authorized GRS® dealer for a complete list of compatible handpieces.

- **A graver or similar tool**

 A properly sharpened graver or similar tool is required to cut through the surface of metal and other materials; use with care. **The dust created while sharpening some tool materials may present a health risk.** Please contact GRS® or an authorized GRS® dealer for a list of available gravers and tools.

REQUIRED EQUIPMENT & IMPORTANT NOTES *(continued)*

- **Clean, dry, oil-free air from an air compressor**



Oil-free compressors are ALWAYS RECOMMENDED. When using an oil-lubricated compressor, install an oil-removal filter (coalescing type – GRS® #004-730 or equivalent) in the air supply line to this engraving system. Damage due to oil or water contamination IS NOT COVERED BY WARRANTY. Even slight amounts of oil can damage internal parts and cause erratic handpiece operation. The supplied final filter is not capable of removing large amounts of water, oil, or contaminants. See *Setup & Connections* for mounting the supplied air filter to engraving system.



If compressed air supply has excessive water, oil, or contaminants, an additional filter/water trap and oil-removal filter (coalescing type) must be installed ahead of the engraving system.

GraverMax® G8 requires a compressed air supply with minimum pressure 45 psi (3 bar) and maximum pressure 120 psi (8 bar). The compressed air supply must have a minimum flow capacity of 1.4 CFM [ft³/min] or 40 LPM [L/min]. To ensure a stable compressed air supply, the user should consider an additional air regulator to adjust the air pressure to 45-60 psi (3-4 bar) before it enters the GraverMax® G8.

- **A sturdy surface with adequate lighting**

Make use of a heavy workbench or suitable solid furniture to support this equipment, workpiece, and any additional equipment and supplies. Adequate lighting allows clear sight, and may help prevent accidents and reduce fatigue.

Placement of this engraving system on the bench is solely user preference and may be determined by left or right hand use during operation.

- **Workholding device or material**

For best results, using a workholding device or material is highly recommended. Properly secure the workpiece to ensure user safety and to guard the piece from damage while working. GRS® manufactures several sizes and types of workholding devices, such as the MagnaBlock, Positioning Vise, MicroBlock vise, Thermo-Loc™ material, and the BenchMate®.

**DO NOT OPERATE ENGRAVING SYSTEM
WITHOUT AN ACTIVE AIR SUPPLY CONNECTED.**

The air supply lubricates the rotary valve as the air passes through the system. No additional lubrication is required.

FIG. 1 • GraverMax® G8 Overview

Front View



Back View



GraverMax® G8 FIG. 1 Diagram

- A. Primary air pressure gauge
- B. Bias control knob
- C. Primary air pressure control knob
- D. Power on/off button
- E. Handpiece selector knob (for H)
- F. Strokes Per Minute (SPM) dial
- G. Auxiliary air open/close knob
- H. Standard Handpiece push-to-connect fittings
- I. Auxiliary Handpiece push-to-connect fitting
- J. Air supply input push-to-connect fitting
- K. Air filter
- L. Air filter bowl drain knob
- M. Air filter output push-to-connect fitting
- N. Air filter input push-to-connect fitting
- O. Foot Throttle push-to-connect fitting
- P. Rubber grommet for stabilizer screw and washer storage—See **UNPACKING THE UNIT**
- Q. 24-volt power receptacle
- R. Reservoir drain plug
(drain located in bottom of base)
- S. Motor mount assembly stabilizer screw



INTRODUCTION

The GraverMax® G8 is an engraving system engineered and manufactured under the GRS® Tools line of products by Glendo LLC in the United States of America. This system is designed for assistance in creating unique works in metal, stone, wood, ivory, and many other materials.



UNPACKING THE UNIT

IMPORTANT SHIPPING NOTE



When unpacking a new GraverMax® G8, notice the screw protruding from the bottom of the machine (FIG. 1.S). This screw is holding the motor mount assembly to protect it from damage during shipping. Remove screw before operation. Use a 7/16" wrench / socket or an adjustable-end wrench to remove screw and washer, then store both by inserting into the rubber grommet located on the back (FIG. 1.P), as shown in the illustration.



For any shipping or transport of this unit, the screw and washer **MUST BE REPLACED** at the bottom of the unit to prevent damage to the motor mount assembly while in transit.



NEVER OPERATE WHILE ON SIDE. Always use the system in a vertical position (FIG. 1).

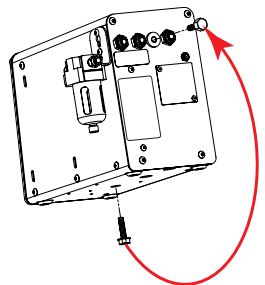
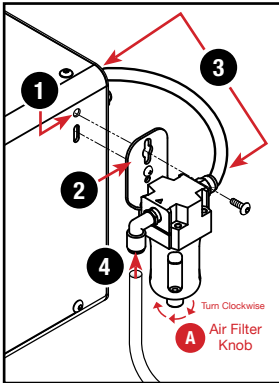

FIG. 2 • Mounting Air Filter to Side



1. Remove top screw from hole.
2. Place screw through top hole on air filter bracket. Tighten screw. *Lower screw keeps filter from swinging freely; do not tighten or remove.*
3. Power off system and air supply. Connect supplied short hose (#044-229) to straight fitting on filter. Connect other end to "Air Input" fitting.
4. Connect hose from air supply to filter fitting marked "N↑".

A Drain water from filter daily. Turn knob clockwise (from top view) to open. Drain. Turn knob counter-clockwise to close valve.

NOTE: If air supply hose is larger than 1/4" (6.35 mm) OD, either replace the push-to-connect fitting with the included barbed fitting and attach the air supply hose or purchase a reducer to decrease the OD to 1/4" (6.35 mm).

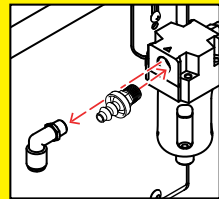
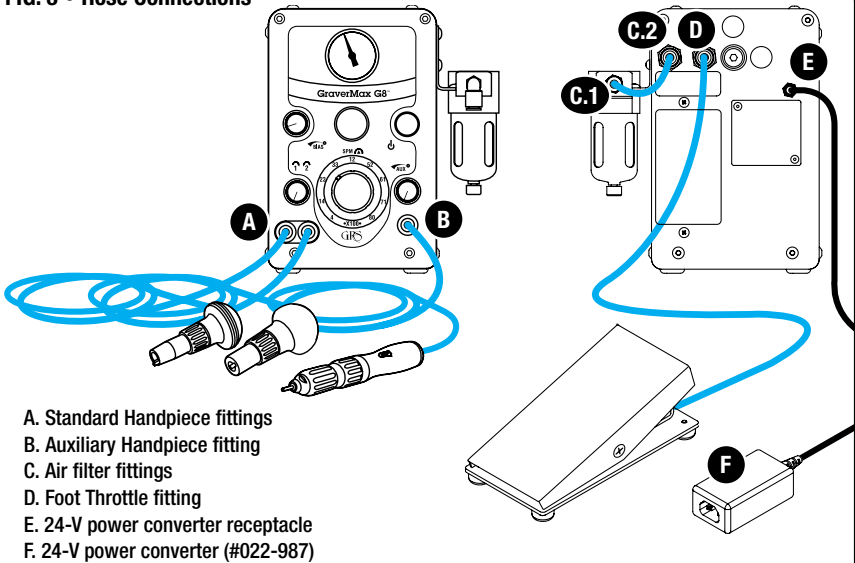

FIG. 3 • Hose Connections



- A. Standard Handpiece fittings
- B. Auxiliary Handpiece fitting
- C. Air filter fittings
- D. Foot Throttle fitting
- E. 24-V power converter receptacle
- F. 24-V power converter (#022-987)

SETUP & CONNECTIONS

MOUNT & CONNECT AIR FILTER

Mount air filter in a location where the air filter may be drained daily (see FIG. 2.A). Refer to FIG. 2 for instructions on mounting the air filter to side of system.

Power off engraving system and air supply. Insert appropriate hose (see FIG. 2.3) into the fitting until the hose stops and is secure. Power on engraving system and air supply to check for leaks and improper connections; air should not escape through any hose or fitting. If air leaks, power off system and air supply. Locate leaks and correct any improper connections. To disconnect from a push-to-connect fitting, press in on the orange ring while gently pulling out the hose.

CONNECT FOOT THROTTLE

Place foot throttle on the floor in a convenient position. Extend throttle hose to back of system (FIG. 3.D) to insert into fitting marked "THROTTLE CONNECTION". The hose should not be pinched or kinked. NOTE: The foot throttle varies handpiece power by controlling the amount of air that flows from the handpiece. While the throttle is depressed, it is normal for air to be released. The user may hear the air being released at times during operation.

CONNECT HANDPIECE(S)

Two handpieces may be connected; only one handpiece can be in operation at any time. Each Standard Handpiece uses a single push-to-connect fitting (FIG. 3.A).

Connect desired handpiece(s) accordingly. The handpiece selector knob above the fittings allows use of either handpiece 1 or handpiece 2 (FIG. 1.E). NOTE: The handpiece selector knob line should point to the selected fitting.

USING AN AIR-DRIVEN ROTARY HANDPIECE

The auxiliary push-to-connect fitting (FIG. 3.B) is a straight flow air port that is limited to 40 psi (2.7 bar) maximum. This is the fitting for a rotary handpiece or other pneumatic tool. The knob is a twist-open/twist-close valve on the front of system (FIG. 1.G).



DO NOT EXCEED 35 psi (2.4 bar) when using the GRS® Ultra 850 Rotary Handpiece.

CONNECT ELECTRICAL POWER



DO NOT OPERATE ENGRAVING SYSTEM WITHOUT AN ACTIVE AIR SUPPLY CONNECTED.

Insert the converter cord into receptacle on engraving system (FIG. 3.E and F). Connect the electrical power cord into the 24-volt power converter. Connect the 3-prong power cord into a properly grounded power outlet, using adapters as needed. See pages 2-3 for details.

OPERATION

STROKES PER MINUTE (SPM)

Stroke speed is a matter of personal preference and experience. The SPM dial (FIG. 4.C) settings are approximate and range from 400–8,000 SPM.

Lower speeds are used for stippling, matting, and similar techniques. Mid-range speeds are used for maximum-power tasks. Higher speeds are used for fine cuts and finishes. Experiment with the settings to better understand how the SPM relates to technique.

FINE ADJUSTMENTS FOR HANDPIECE OPERATION

PROPERLY ADJUSTING THE ENGRAVING SYSTEM IS THE SINGLE MOST IMPORTANT OPERATION TO LEARN. Each handpiece has a normal SPM range. Operating outside this range can produce erratic results.

SPECIAL NOTE: When powered on, the system pushes a small amount of air through the electrically-controlled air solenoid valve. When powered off, the system seals the valve, making a “pop” and “hiss” sound. This allows the system to be powered off while the air compressor remains on—without loss of air in the compressor tank.

- Power on the air compressor and allow tank to fill. **Wait for the compressor to cycle off.**
- Power on the GraverMax® G8. **Turn the bias control knob clockwise until closed.** Turn the handpiece selector knob to choose connected handpiece.
- Turn the SPM dial (FIG. 4.C) to 2300. Turn the primary air pressure control knob (FIG. 4.B) clockwise until the air pressure gauge displays 5 psi (0.4 bar).
- Hold the selected handpiece vertically near either ear as shown in FIG. 5.
- **WITHOUT operating the throttle,** slowly increase the air pressure until the handpiece begins to buzz. The handpiece will vibrate, then knock, as the pressure increases. Stop adding air pressure immediately after the knocking stops. This is the perfect air pressure operating range for the selected handpiece model.

See chart on page 9 for an alternative adjustment method.

FIG. 4 • Primary Control Knobs

- A. Bias control knob
- B. Primary air pressure control knob
- C. Strokes Per Minute (SPM) dial

Make sure the bias control knob is closed before adjusting the machine.

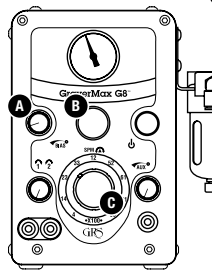

FIG. 5



Alternatively, the settings in the chart may be used for adjusting the selected handpiece; this method is not as precise. Set the SPM dial and the air pressure control knob to the *Recommended Initial Setting* for the selected handpiece.

HANDPIECE FINE ADJUSTMENT SETTINGS

Handpiece	Item Number	Type	Normal Operating Range <i>Strokes Per Minute</i>	Normal Air Pressure Range <i>psi (bar)</i>	Recommended Initial Setting	
					<i>Strokes Per Minute</i>	<i>Air Pressure psi (bar)</i>
Magnum®	004-940		800-3400	18-22 psi (1.2-1.5 bar)	2400	20 psi (1.4 bar)
901®	004-901, 004-910	Standard	1400-4000	17-22 psi (1.2-1.5 bar)	2400	19 psi (1.3 bar)
		Fine	1400-4000	12-15 psi (0.8-1.0 bar)	2400	13 psi (0.9 bar)
Monarch™	004-921, 004-926	Standard	2000-5000	10-13 psi (0.7-0.9 bar)	3000	11 psi (0.8 bar)
		Fine	2000-5000	6-8 psi (0.4-0.6 bar)	3000	7 psi (0.5 bar)
Maestro™ MX	004-909		600-3200	18-22 psi (1.2-1.5 bar)	2200	20 psi (1.4 bar)
Maestro™ EX	004-905		800-3600	17-22 psi (1.2-1.5 bar)	2200	19 psi (1.3 bar)
Maestro™	004-947		2000-5000	10-13 psi (0.7-0.9 bar)	3000	11 psi (0.8 bar)
QC 720	004-720		400-3000	18-26 psi (1.2-1.8 bar)	1600	22 psi (1.5 bar)
QC 710	004-710		800-3000	20-24 psi (1.4-1.7 bar)	1800	21 psi (1.4 bar)
610 Hammer	004-610, 004-609		800-3000	20-24 psi (1.4-1.7 bar)	1800	21 psi (1.4 bar)
QC 801	004-801, 004-810	(obsolete)	1400-4000	20-24 psi (1.4-1.7 bar)	2400	22 psi (1.5 bar)
506 Large	004-506	(obsolete)	400-3000	18-26 psi (1.2-1.8 bar)	1600	22 psi (1.5 bar)
508 Standard	004-508	(obsolete)	800-3000	18-22 psi (1.2-1.5 bar)	2000	20 psi (1.4 bar)

OPERATION *(continued)*

HANDPIECE ADJUSTMENT TROUBLESHOOTING

The system will be difficult to control if the air pressure or SPM is incorrect. Use the lowest air pressure setting to provide proper operation; do not set the air pressure higher than needed.

- Handpiece vibrates or knocks without using the Foot Throttle: air pressure is too low; increase to proper air pressure.

- Handpiece power decreases at full throttle: air pressure is too low or the SPM is too high; reset pressure or SPM.

- Handpiece does not operate within 3/8" (9.525 mm) of depressing foot throttle: air pressure is too high; decrease to proper air pressure.

Make fine adjustments in air pressure or SPM until proper operation is attained. The handpiece will operate smoothly and predictably once adjusted properly. With more experience, experiment with variations in air pressure and SPM to suit preferences.

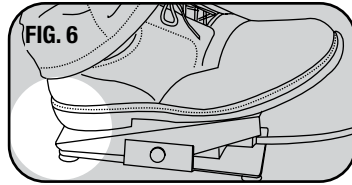

FOOT THROTTLE OPERATION

For foot throttle operation, set the engraving system to "foot" control as follows.

- Place foot on throttle as shown in FIG. 6, with heel completely on the foot throttle and not on the floor.

- Before depressing foot throttle, position handpiece and tool properly. The tool should rest firmly on the material surface before operating the foot throttle.

After handpiece is adjusted properly, depress the foot throttle to activate the handpiece. To increase power when cutting deeper, depress the Foot Throttle as needed to increase handpiece power. It may take practice to coordinate foot action with the need for more power.

Rely on increasing the power provided by the foot throttle to the handpiece instead of manually pushing the handpiece through the cut. Manual pushing is an incorrect use of the handpiece and can result in the tool slipping.

At the start of the cut, smoothly increase power; as more power is needed, depress the foot throttle more. As the cut reaches the end, gradually reduce foot throttle pressure and quickly guide the graver up and out.

OPERATION *(continued)*

HANDPIECE OPERATION

Unlike traditional or push engraving where a firm grip and manual forward force is required, the GRS® pneumatic handpiece requires only a light grip and guidance.

Relax, allowing the engraving system to move the tool forward and through the material with guidance. Most graver slips are due to manual hand pushing and an overly-firm grip on the handpiece.

A tight grip actually lessens impact power. For heavy work, decrease grip while increasing power with the foot throttle; an increasingly relaxed grip will increase the power. However, do not lose control while guiding the tool.

For general cutting techniques, position the handpiece as in FIG. 7.A; this is similar to holding a dinner knife. For stippling, hammering, or similar techniques, position the handpiece as in FIG. 7.B; this is similar to holding a pencil.

For hammering work, press the hammer tip down firmly to the material surface and then operate the foot throttle. This system is not like a flexible-shaft hammer; do not operate the hammer tool by holding the tip slightly above the surface. Use just enough downward pressure to keep the hammer in place while working.

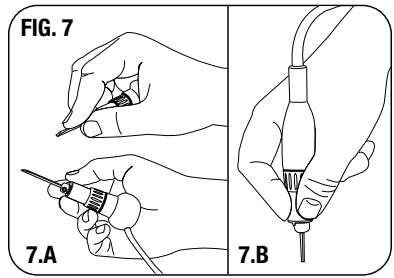

ADJUSTMENTS USING THE BIAS CONTROL

Use the bias control to adjust the starting position of the foot throttle. This feature may be useful for fine detail work such as bulino engraving. Open the bias control fully to activate the handpiece without depressing the foot throttle. This feature may be useful for stippling or hammering.

- Turn the primary air pressure control knob (FIG. 4.B) to add 1-2 psi (0.07-0.14 bar) air pressure to the current setting.
- Turn the bias control (FIG. 4.C) slightly to open the bias valve, just until the handpiece is activated; then slowly close the bias valve when the handpiece stops stroking. Note the foot throttle requires less pressure to activate the handpiece.

FIG. 10

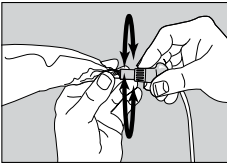
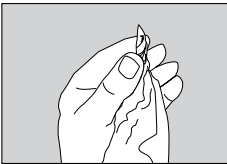
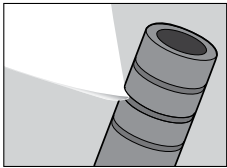
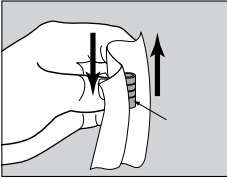
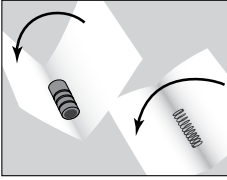

MAINTENANCE

HANDPIECE

Keep the handpiece clean for proper operation. Cleaning is necessary if operation becomes sluggish, erratic, or fails. Refer to FIG. 10 and the instructions below for the proper way to clean a handpiece.

- Remove the piston and spring from the handpiece.
- Wrap each separately in a sheet of writing or printing paper.

⚠ DO NOT USE paper towel, tissue, or newsprint.

- Hold the wrapped piece. Buff and polish each piece with the paper to remove any dirt or residue.

- Remove piece from paper. For grooved pistons, fold paper to create a thick edge. Insert the paper edge in each piston groove. Use the same folded paper to clean open space in spring.

- Twist the paper to a point that will fit into the handpiece barrel. Insert and rotate the paper to buff and polish the inside until clean.

- Reassemble handpiece.

⚠ IMPORTANT NOTE: DO NOT LUBRICATE PISTON, SPRING, OR BORE.

FOOT THROTTLE

The throttle requires little maintenance with proper use. Remove any dust, debris, and metal chips from foot throttle to clean periodically. Place a drop of oil on the throttle hinges to prolong spring life and prevent rust. When sweeping or vacuuming, place foot throttle on bench or chair.

GRS® ULTRA 850 ROTARY HANDPIECE

Refer to the GRS® 850 operating instructions for routine maintenance of the rotary handpiece.

⚠ DO NOT EXCEED 35 psi (2.4 bar) during operation.

IMPORTANT NOTICES

GRS® PROGRESSIVE FOOT THROTTLE OWNERS

The GRS® Progressive Foot Throttle will operate properly with this engraving system. Attach the GRS® Progressive Foot Throttle to the “THROTTLE CONNECTION” push-to-connect fitting on the back of the system.

AIR CONTAMINANTS AND WATER ACCUMULATION

If large amounts of water and contaminants are in the air supply to the system, the bowl must be drained frequently to prevent water from entering the rotary valve, hoses, handpiece, etc. Check all filters, bowls, hoses, etc., twice a week to prevent accumulation.

Additionally, the filter element must be cleaned and/or replaced frequently. If moisture is noted in the handpiece or throttle hoses, power off system immediately. Purge air from system, drain filter bowl, and proceed as follows:

- Disassemble and clean handpiece(s). Reassemble.
-
- Set primary air pressure to 10 psi (0.7 bar). Power on the system to purge moisture from valves, hoses, etc.
-
- Locate the drain plug to the internal air reservoir (FIG. 1.R). Use a 3/16" hex wrench to remove the plug; drain any moisture from reservoir. Replace drain plug.
-
- Before powering on engraving system, locate source of moisture and correct problem. An additional filter or water trap in the air line may be necessary.

SERVICE & REPAIR

Please call GRS® or an authorized GRS® dealer to order replacement parts and for instructions on replacement. Do not attempt to service parts that must be sent to GRS® or an authorized GRS® dealer; these must be repaired or replaced by GRS® or an authorized GRS® dealer. Servicing parts not signified as operator serviceable will void the 2-year warranty. **Any part not noted as replaceable or serviceable by the operator must be sent in to GRS® or an authorized GRS® dealer for repair.**

ORDER REPAIR OR REPLACEMENT PARTS

These parts are replaceable by the operator. Normal Wear and Tear, Abuse, Misuse, or Loss are not covered by warranty. See illustrations on page 15.

RHMS, #8-32 x 0.25" Z/P	002-568
Tubing, PU CLR 0.250" O.D., 0.170" I.D. (Foot Throttle Hose)	004-050
Fitting, PTC 0.25" 90° M1/8" NPT	022-230
Fitting, PTC 0.25" Inline M1/8" NPT	022-231
Assembly, 5-Micron Filter and Bowl	022-944
RHMS, M4 x 0.7MM [Qty: 2]	022-978
Bracket, Filter Mount	044-051
Tubing, PU CLR 0.250" O.D., 0.130" I.D.	044-229
Allen Wrench, 1/8"	022-053
Square Point Graver	002-115
#4 QC HSS Onglette Graver	022-404
Small Steel Point [Qty: 2]	002-979
Fitting, B-1/4" I.D. TUBE M1/8" NPT	002-361
Power adapter	022-872, 022-987, 022-993
Foot Throttle (Hose 004-050 not included)	004-519

OPERATOR SERVICEABLE PARTS

Call GRS® or an authorized GRS® dealer for instructions and ordering information before attempting to service or replace these parts.

GraverMax® G8 Box Parts	page 20
Motor Assembly (not Motor Valve Assembly)	page 21

GraverMax[®]G8AccessoriesAccessories

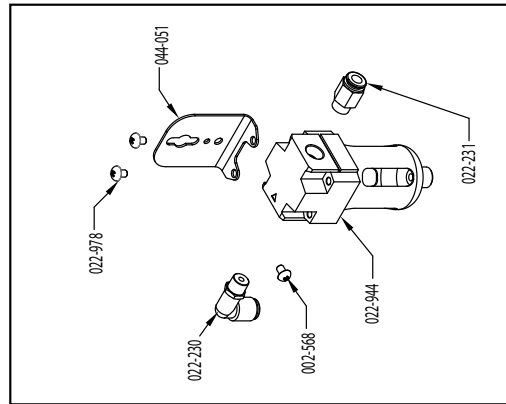

Order Replacements:

- 022-860 1 BOWL & COVER REPLACEMENT
- 022-861 1 FILTER REPLACEMENT

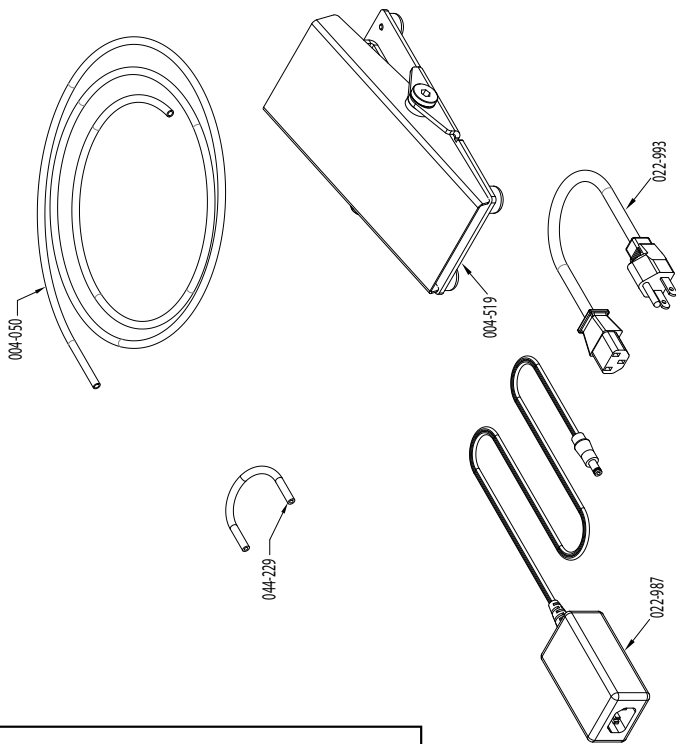

GraverMax® G8 Front Face Plate & Motor Valve Parts ListFr

PART NO.	QTY.	DESCRIPTION	PART NO.	QTY.	DESCRIPTION
002-280	3	WASHER, 0.50" O.D. 0.25" I.D. x 0.13" NY	022-967	1	FITTING, PTC 0.25" 45° M1/8" NPT
002-333	1	O-RING, 0.313" O.D. 0.188" I.D.	022-970	1	SWITCH, ILLUMINATED POWER
002-369	1	SHSS, #10-32 x .19" BLK	022-980	1	REGULATOR, PRECISION AIR
002-487	1	WASHER, 1.0" O.D. 0.44" I.D. x 0.08" Z/P	022-982	3	KNOB, GRAY 0.75" O.D. 0.25" I.D. x 0.69"
002-615	1	GAUGE, 1.63" O.D. 0-60psi/AIR	022-983	1	KNOB, B-G 1.75" O.D. 0.25" I.D. x 0.78"
002-766	1	CLAMP, WIRE, 0.25" O.D. TUBE	024-043	1	DECAL, GraverMax®G8 FRONT
002-971	1	PLUG, 0.190" O.D. x 0.125" SINTERED	044-036	1	PLATE, FRONT COVER
002-977	1	O-RING, 0.188" O.D. 0.063" I.D.	044-044	1	NEEDLE, VALVE
004-033	1	VALVE BODY	044-052	1	PLATE, FRONT FRAME
004-501-V2	1	VALVE, 2-WAY SWITCHING	044-056	1	VALVE SHIFTER SHAFT
004-812	1	WIRE, R-L-B-22AWG POT F-SPADE	044-065	1	TUBING, PU CLR 0.250" O.D. 0.170" I.D.
004-814	1	WIRE, R-22AWG F-SPADE T-RING	044-065	1	TUBING, PU CLR 0.250" O.D. 0.170" I.D.
004-814	1	WIRE, R-22AWG F-SPADE T-RING	044-066	1	TUBING, PU CLR 0.250" O.D. 0.170" I.D.
004-822	1	WIRE, B-22AWG F-SPADE T-RING	044-068	1	TUBING, PU CLR 0.250" O.D. 0.170" I.D.
022-230	2	FITTING, PTC 0.25" 90° M1/8" NPT	044-073	1	BRACKET, GAUGE MOUNTING
022-231	3	FITTING, PTC 0.25" INLINE M1/8" NPT	044-095	1	TUBING, PU CLR 0.250" O.D. 0.170" I.D.
022-315	1	GROMMET, 0.88" O.D. 0.63" I.D. RUBBER			
022-875	1	VALVE, PTC 0.25" NEEDLE			
022-966	1	FITTING, PTC 0.25" 90° F1/8" NPT			

GraverMax® G8 Motor Valve Assembly Motor Valve Assembly

PART NO.	QTY.	DESCRIPTION
004-951	1	VALVE BODY, ROTARY
022-230	2	FITTING, PTC 0.25" 90° M1/8" NPT
022-948	1	O-RING, 1.078" O.D., 0.938" I.D.
022-977	1	FITTING, PTC 0.25" T M-1/8" NPT
022-990	1	WASHER, 0.63" O.D., 0.41" I.D. x 0.03" NY
044-006	1	VALVE SHROUD, ROTARY

Contact GRS® or an authorized GRS® dealer for replacement parts or repairs.
 Visit grs.com/dealers for dealers in your country.

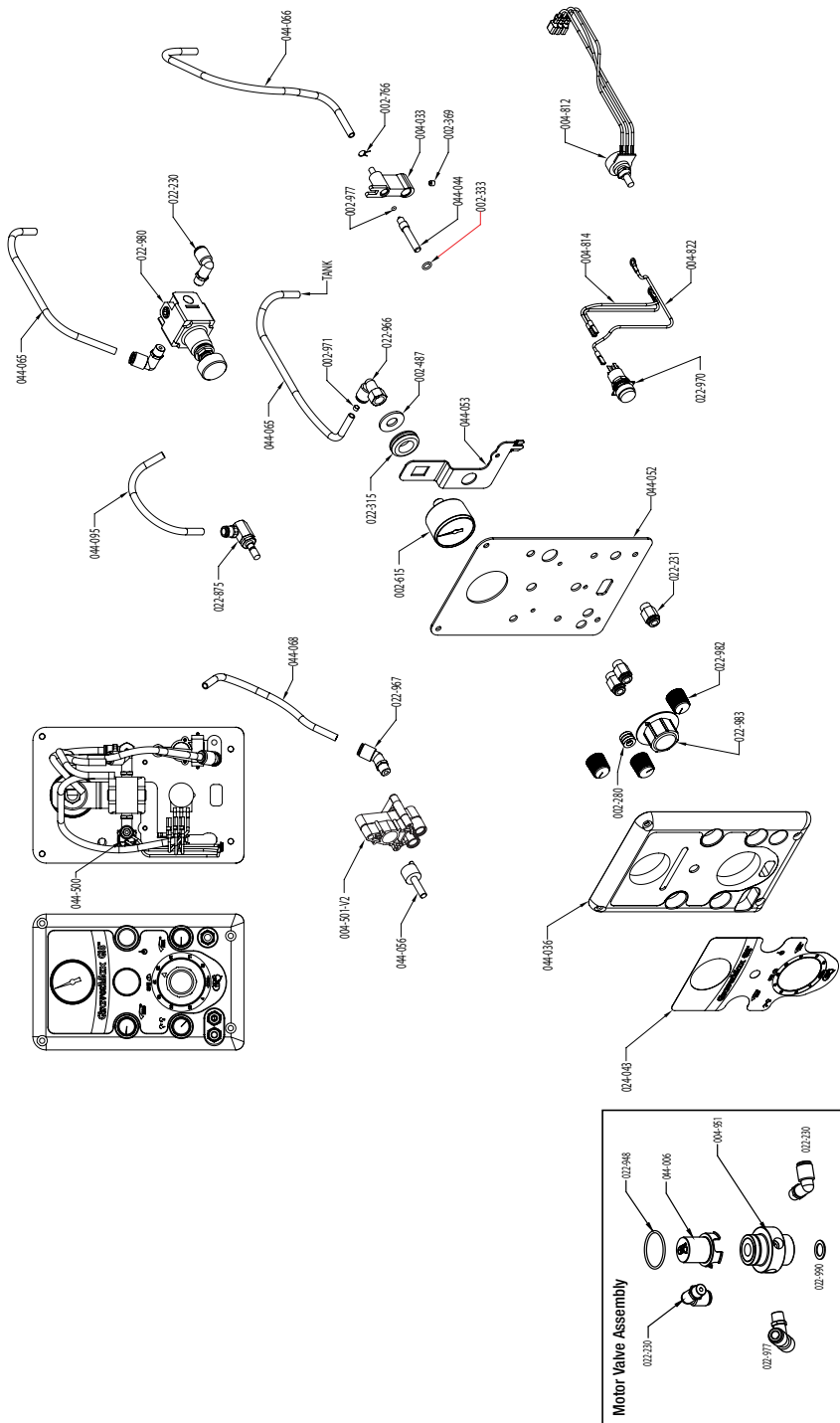

GraverMax® G8 Back Parts List

PART NO.	QTY.	DESCRIPTION
002-062	2	RHMS, #8-32 x 0.5" Z/P
002-092	2	TERMINAL, 22-16AWG #10 RING
002-104	2	NUT, #8-32 HEXKEP Z/P
002-186	2	RIVET, 0.125" DIA. x 0.125" POP
004-809	1	WIRE, B-22AWG T-RING T-RING
004-811	1	WIRE, B-R-22AWG P-JCK F-SPD T-R
004-815	1	WIRE, R-22AWG F-SPADE T-RING
004-816	1	WIRE, B-22AWG F-SPADE T-RING
004-817	1	WIRE, R-22AWG F-SPADE F-SPADE
004-818	1	WIRE, B-22AWG F-SPADE F-SPADE
022-245	1	GROMMET, 0.5" O.D. 0.188" I.D. RUBBER
022-962-R-PART	1	CONTROLLER, 24VDC PWM MTR
022-965	2	FITTING, PTC 0.25" BULKHEAD
024-036	1	VALVE, 24VDC SOLENOID
024-042	1	FITTING, PTC.25" M#10-32
024-118	2	NUT, #4-40 HEX Z/P
024-119	2	RHMS, #4-40 X .63" Z/P
044-055	1	PLATE, REAR FRAME
044-059	1	DECAL, AIR INPUT/THROTTLE
044-070	1	TUBING, PU CLR 0.25" O.D. 0.17" I.D.
044-111	1	TUBING, PU CLR .250"OD .130"ID
044-137	1	TUBING, PU CLR .250"OD .130"ID
044-222	1	BRACKET, SOLENOID
044-235	1	SERIAL PLATE, GraverMax® G8
LIT-294	1	DECAL, DRY AIR NOTICE

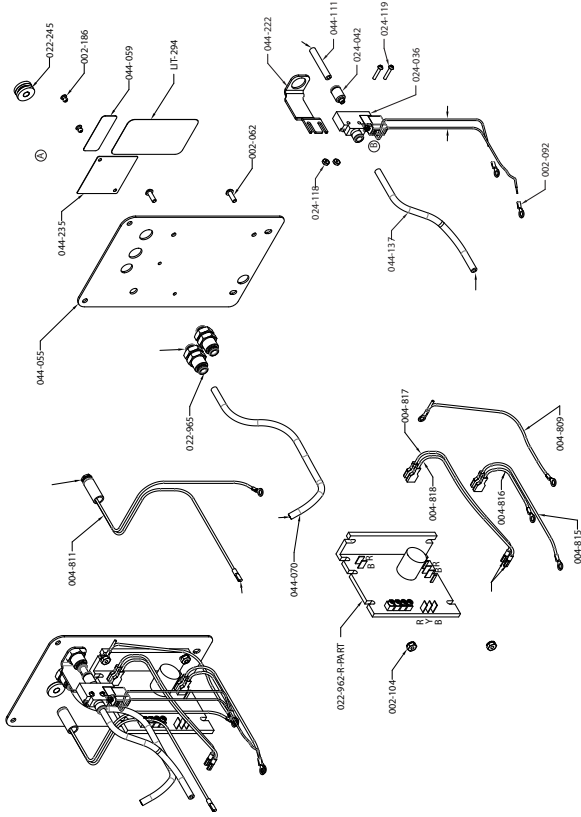

Contact GRS® or an authorized GRS® dealer for replacement parts or repairs.
 Visit grs.com/dealers for dealers in your country.

GraverMax® G8 Base Parts List

PART NO.	QTY.	DESCRIPTION
002-536	3	NUT, 1/4"-20 FLNG LOCK Z/P
011-209	4	FOOT, #8-32 x 0.5" RUBBER
022-222	3	SOCKET HEAD CAP SCREW
022-230	1	FITTING, PTC 0.25" 90° M1/8" NPT
022-231	3	FITTING, PTC 0.25" INLINE M1/8" NPT
022-381	1	PLUG, 1/8"-27NPT x 0.25" PIPE
022-964	6	BHSCS, #10-32 x 0.38" BLK
024-168	3	SPECIAL WASHER
024-169	1	O-RING
044-035	1	PLATE, BASE FRAME
044-060	1	TANK, AIR SUPPLY
044-256	1	MOLDED AIR TANK (FOUR HOLE VERSION)

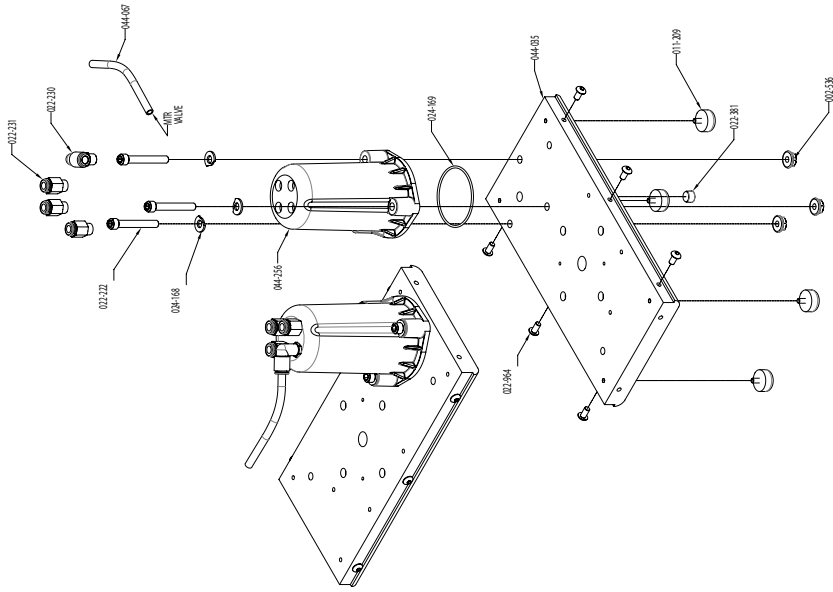

GraverMax® G8 Box Parts List

PART NO.	QTY.	DESCRIPTION
001-425	1	WASHER
002-062	2	RHMS, #8-32 x 0.5" Z/P
002-288	4	SHCS, #10-32 x 5/8" BLK
022-870	1	HHCS, 1/4"-20 x 1.25" P-LOK Z/P
022-963	4	SPRING, COMP 0.3" O.D. 0.57" FL
022-964	4	BHSCS, #10-32 x 0.38" BLK
022-999	2	RHMS, #6-32 x 1.75" Z/P

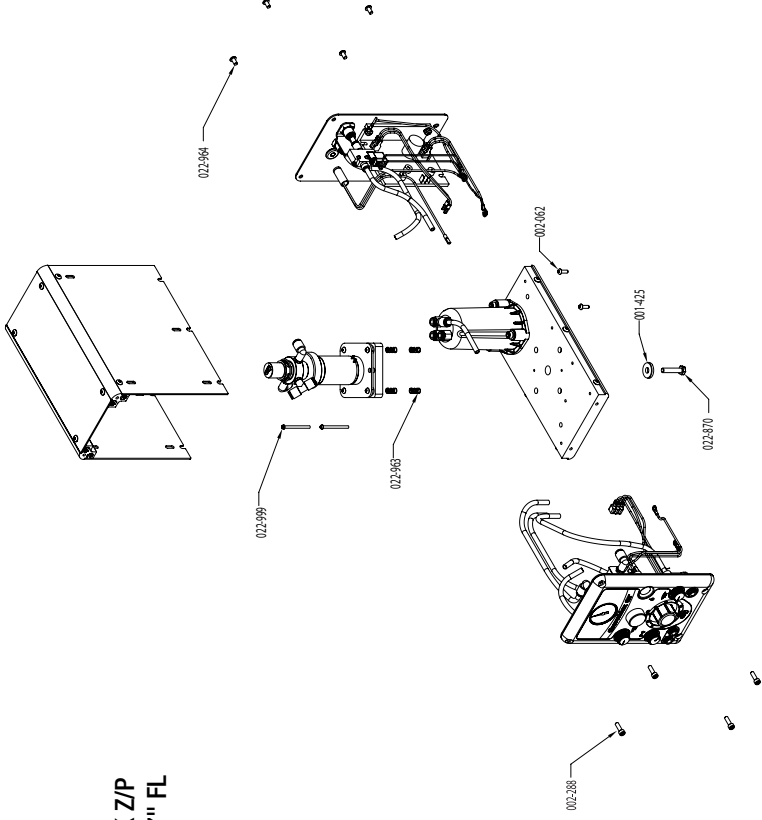

Contact **GRS®** or an authorized **GRS®** dealer for replacement parts or repairs. Visit grs.com/dealers for dealers in your country.

GraverMax® G8 Motor Assembly

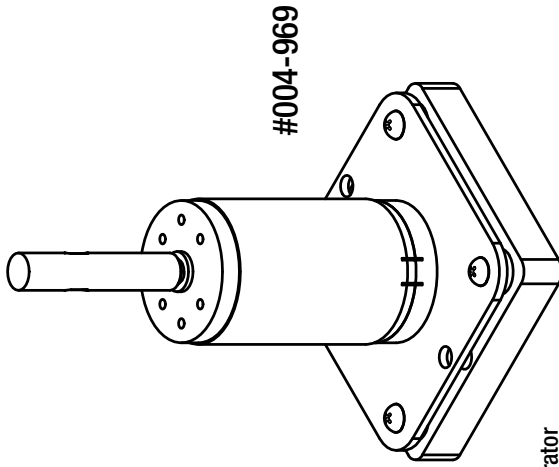

Motor Assembly

The Motor Assembly is operator replaceable. Contact GRS® or an authorized GRS® dealer for details.

Contact GRS® or an authorized GRS® dealer for replacement parts or repairs. Visit grs.com/dealers for dealers in your country.

GraverMax® G8 Wiring Diagram

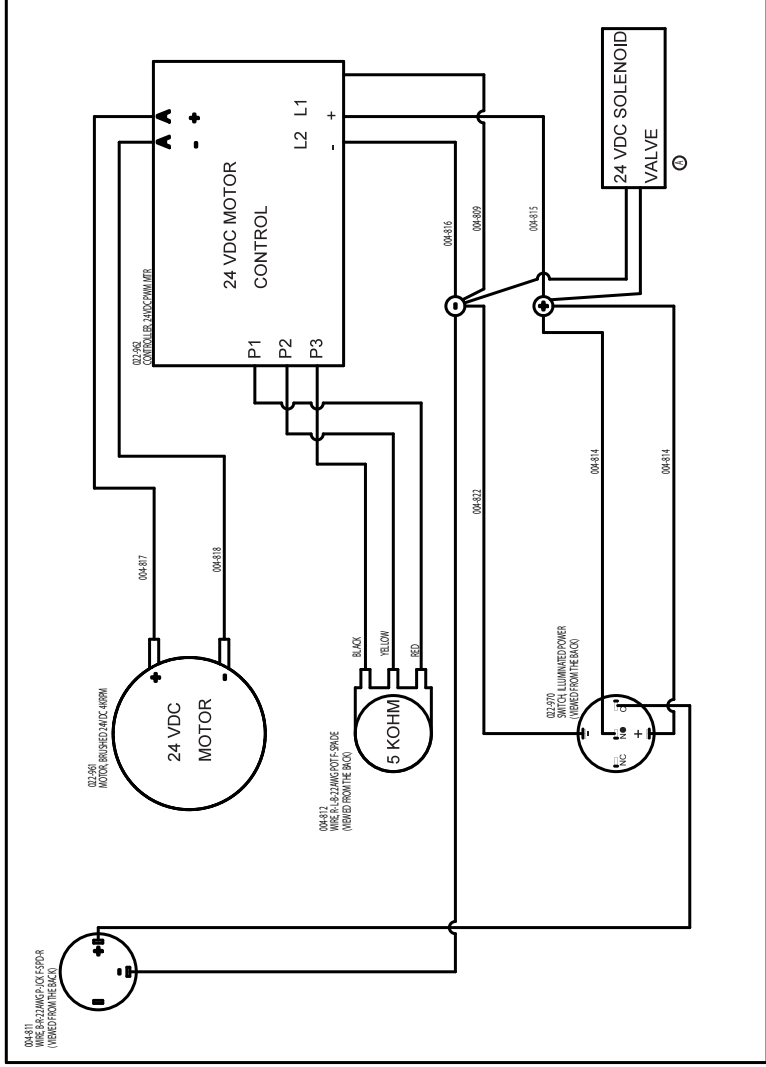

GraverMax® G8 Hose Diagram

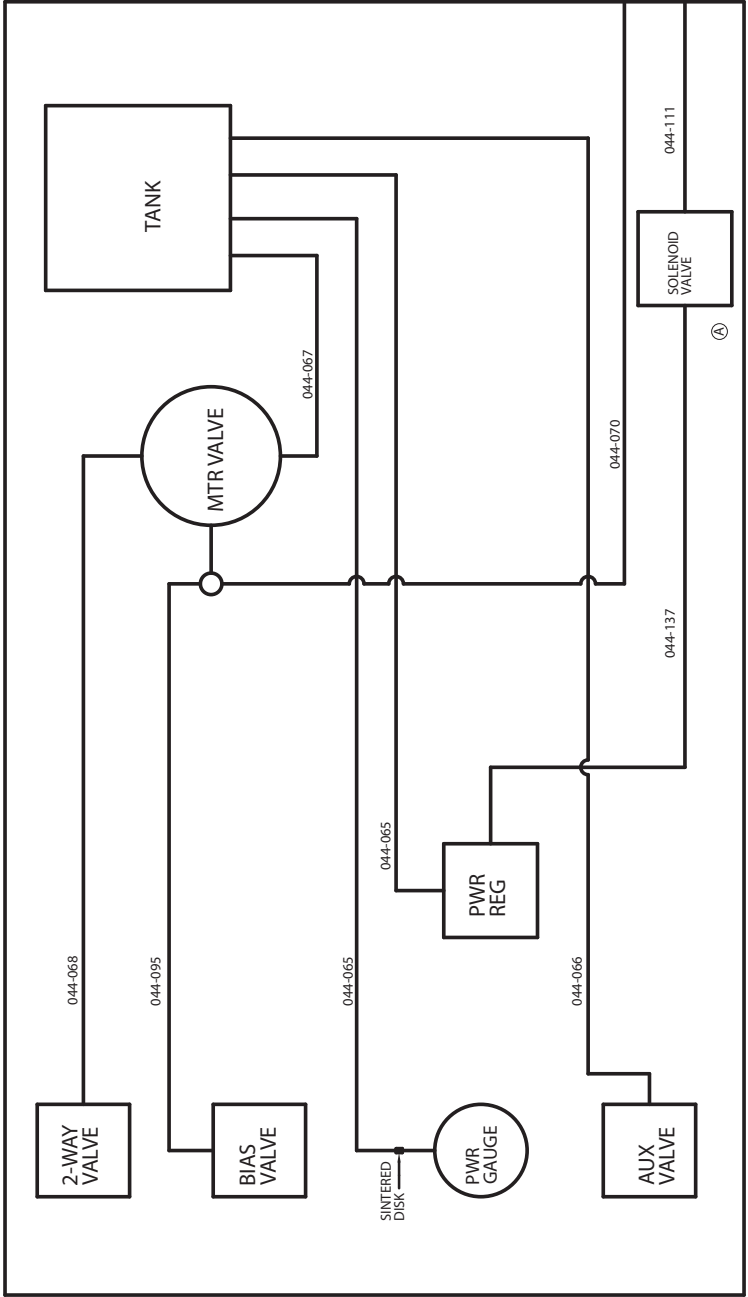

BACK PANEL

NOTES:

NOTES:

WARRANTY

Each GraverMax® G8, including provided foot throttle, carries a full 2-year warranty covering parts and labor. Contact GRS® or an authorized GRS® dealer before returning any equipment.

 These products are designed for reliable operation using most sources of compressed air. However, some air supplies contain excessive water, oil, dirt, rust, or other contaminants. The built-in filter of the engraving system is a final filter to protect against normal dirt and water. If the compressed air has excessive contaminants, install the necessary filter(s) and water trap(s) ahead of the engraving system.

 Oil contamination can be gradual and subtle. If an oil residue (usually yellow or brown, sticky or liquid) becomes present in the filter bowl of the engraving system, or in the handpiece / throttle hose, the compressed air most likely contains oil or contaminants. Older oil lubricated and “silent” compressors that use internal oil are more likely to cause oil contamination. If this occurs, install a Coalescing Oil Filter (GRS® #004-579 or equivalent).

NOTE: Damage caused by contaminated compressed air is not covered by the warranty.



Glendo LLC

900 Overlander Road
Emporia, KS 66801 USA

Phone: +1-620-343-1084

Fax: +1-620-343-9640

E-mail: glendo@glendo.com

www.grs.com

GraverMach® AT, GraverMach®, GraverMax® G8, GraverMax® SC, GraverMax®, GraverMate®, GraverSmith, BenchMate®, GraverMeister®, MicroBlock®, Airtact®, MagnaBlock™, and GraverHone® VS are trademarks of Glendo LLC. Covered by USA and foreign patents. Printed in USA. Products made in USA.

© 2009–2022 Glendo LLC. All rights reserved.
