

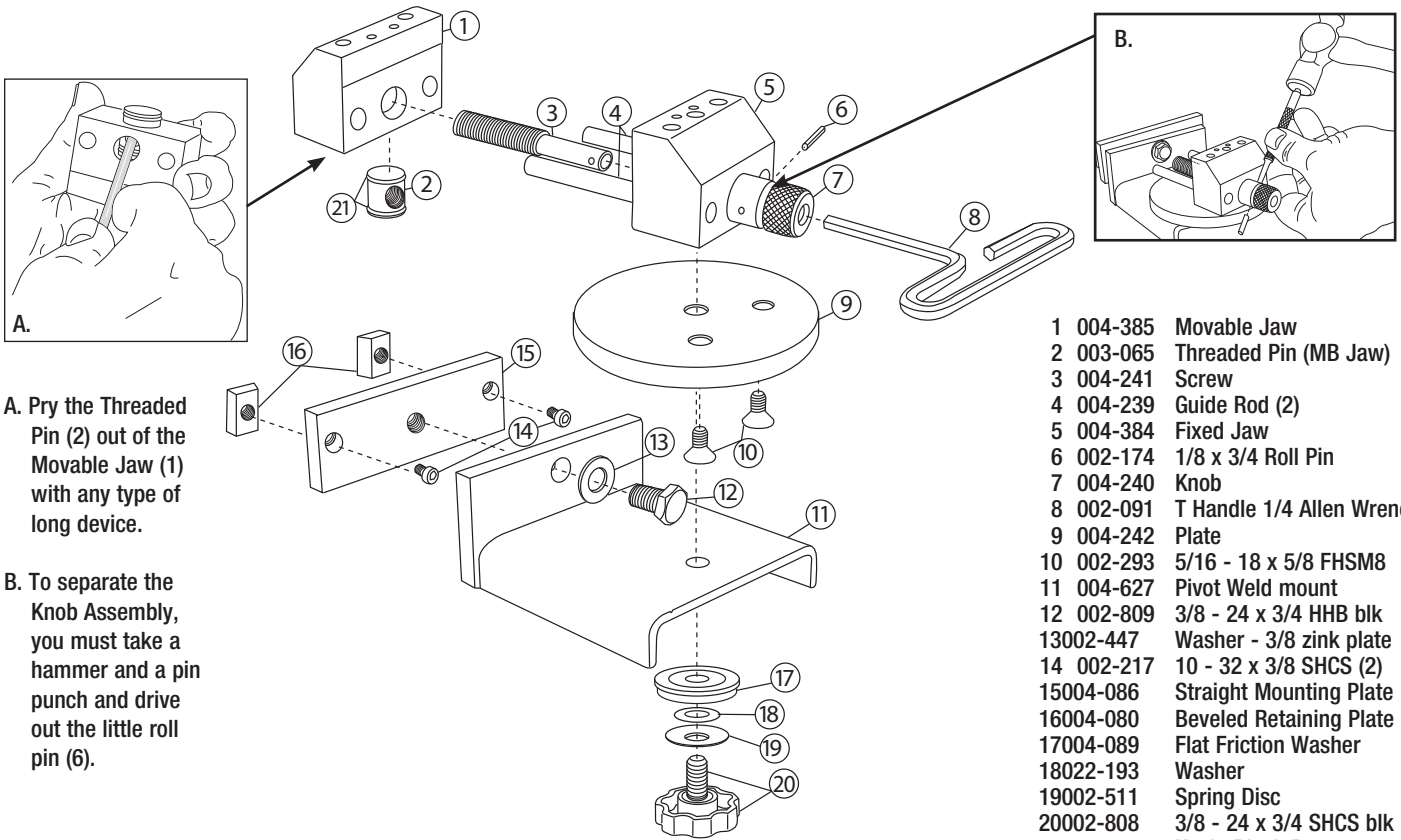

Multi-Purpose Vice for BenchMate® System

PART #004-628

INSTRUCTIONS FOR REPAIR AND REPLACE ONLY





A. Pry the Threaded Pin (2) out of the Movable Jaw (1) with any type of long device.

B. To separate the Knob Assembly, you must take a hammer and a pin punch and drive out the little roll pin (6).

- 1 004-385 Movable Jaw
- 2 003-065 Threaded Pin (MB Jaw)
- 3 004-241 Screw
- 4 004-239 Guide Rod (2)
- 5 004-384 Fixed Jaw
- 6 002-174 1/8 x 3/4 Roll Pin
- 7 004-240 Knob
- 8 002-091 T Handle 1/4 Allen Wrench
- 9 004-242 Plate
- 10 002-293 5/16 - 18 x 5/8 FHSM8
- 11 004-627 Pivot Weld mount
- 12 002-809 3/8 - 24 x 3/4 HHB blk
- 13002-447 Washer - 3/8 zink plate
- 14 002-217 10 - 32 x 3/8 SHCS (2)
- 15004-086 Straight Mounting Plate
- 16004-080 Beveled Retaining Plate (2)
- 17004-089 Flat Friction Washer
- 18022-193 Washer
- 19002-511 Spring Disc
- 20002-808 3/8 - 24 x 3/4 SHCS blk
- 002-512 Knob, Black Rosett
- 21002-127 O-ring, .625 x .75 x .062 (2)

This vise requires the Fixed Mounting Plate part #004-557

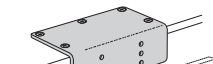
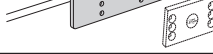
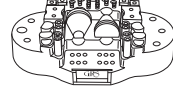
ACCESSORIES:

PART NO.		DESCRIPTION
004-559		Optional Mounting Adapter <i>For attaching Fixed Mounting Plate to curved or thin bench tops</i>
004-557		Fixed Mounting Plate
003-520MPV		Attachment Set for Multi-Purpose Vise <i>Includes 30-pc. attachment set, two pin plates and 4 jaw pins</i>
003-662		1/4" Hex Drive Key with Knurled Aluminum Handle <i>Low profile design that is handy and easy to grip. Replacement for the T-handle.</i>

CONTACT YOUR SALES REPRESENTATIVE OR VISIT GRS.COM FOR PRICING AND AVAILABILITY

GLENDO LLC

900 Overlander Road • Emporia, KS 66801 USA
 800-835-3519 • 620-343-1084 • Fax: 620-343-9640
 grs@grstools.com • grs.com
 Last Update: 2021-03-30