

INSIDE RING MANDREL

PART #004-589

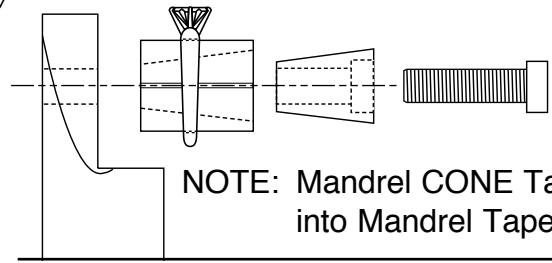

NOTE: Mandrel CONE Taper fits into Mandrel Taper

INSTRUCTIONS:

To hold a ring VERTICAL

Insert the bolt through the mandrel cone and place cone into the tapered end of the mandrel you have selected. (See Illustration above) Position ring on the selected mandrel. Turn the bolt into the Ring Post with the supplied wrench until the ring is snug.

DO NOT OVER TIGHTEN - Damage may occur to the ring being held.

To hold a ring HORIZONTAL

Turn the Ring Post upside down and use the threaded hole on the bottom to secure the mandrel and cone assembly. Place Stop Pin into the side hole located closest to work end for use in a Bench Mate®.

Post may be held by hand or secured in a BenchMate® bracket.

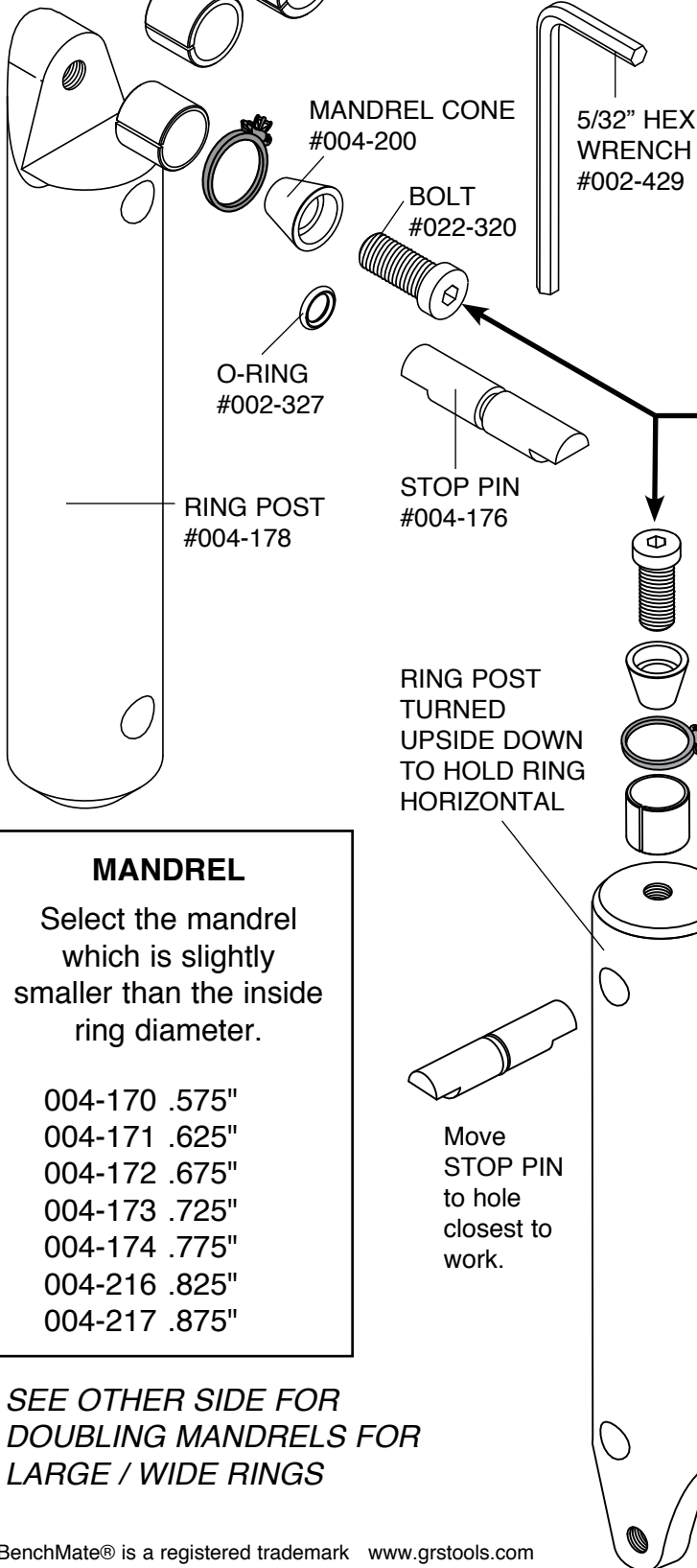
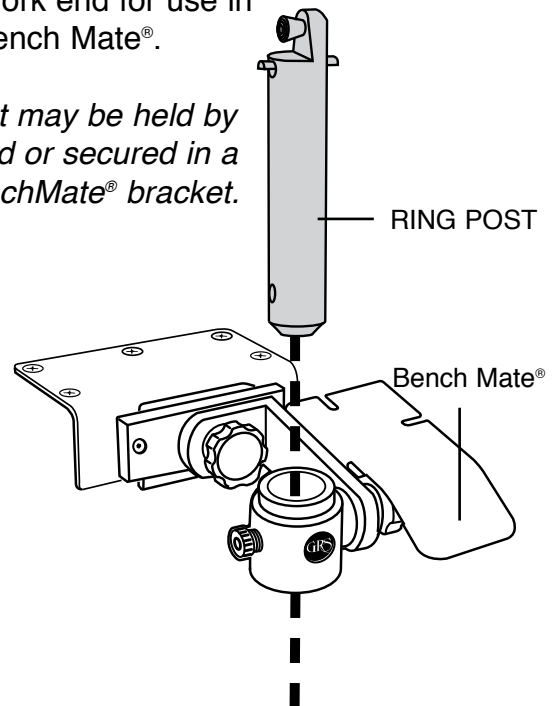

MANDREL
See size chart below

MANDREL CONE
#004-200

5/32" HEX
WRENCH
#002-429

BOLT
#022-320

O-RING
#002-327

RING POST
#004-178

STOP PIN
#004-176

RING POST
TURNED
UPSIDE DOWN
TO HOLD RING
HORIZONTAL

Move
STOP PIN
to hole
closest to
work.

MANDREL

Select the mandrel which is slightly smaller than the inside ring diameter.

- 004-170 .575"
- 004-171 .625"
- 004-172 .675"
- 004-173 .725"
- 004-174 .775"
- 004-216 .825"
- 004-217 .875"

SEE OTHER SIDE FOR
DOUBLING MANDRELS FOR
LARGE / WIDE RINGS



EXTRA SET OF MANDRELS FOR LARGE RINGS



PART #004-616

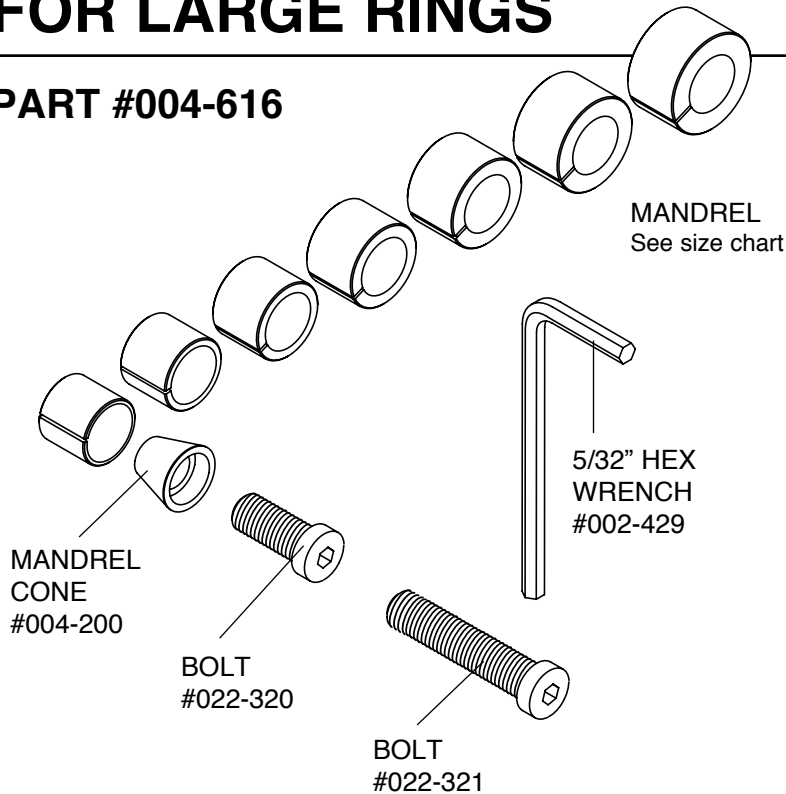

MANDREL

Select the mandrel which is slightly smaller than the inside ring diameter.

- 004-170 .575"
- 004-171 .625"
- 004-172 .675"
- 004-173 .725"
- 004-174 .775"
- 004-216 .825"
- 004-217 .875"

NOTE: Mandrel CONE Taper fits into Mandrel Taper

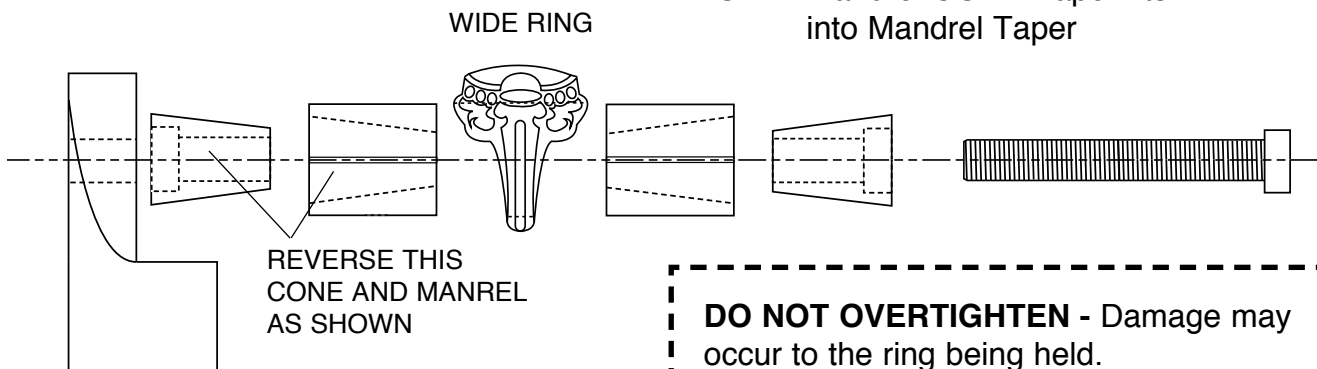

INSTRUCTIONS:

To hold a ring VERTICAL

To hold large / wide rings use TWO of the SAME SIZE mandrels and TWO mandrel cones. Insert the long bolt through the first mandrel cone and place cone into the tapered end of the mandrel you have selected. Then reverse the second mandrel and place on bolt. Slide the second cone into that mandrel so that the taper angles match. (See Illustration above) Position ring on the selected mandrel. Tighten the socket head screw into the Ring Post with the supplied wrench until the ring is snug.

To hold a ring HORIZONTAL

Turn the Ring Post upside down and use the threaded hole on the bottom to secure the mandrel and cone assembly. Switch the Stop Pin to the side hole that is closest to the work for use in a BenchMate®.

*SEE OTHER SIDE FOR
MORE INFORMATION*